

32-1107 REV 2

The lever-operated TSB100 test stand is ideal for quick-action tensile testing and compression testing of up to 100 lbf (500 N) of force. Constructed of rugged components, this test stand is durable enough for the factory floor, yet precise enough for laboratory environments.

Specifications

Load Capacity:	100 lbf [500 N]
Maximum Travel:	With travel stops: 2.75 in [69.9 mm] Without travel stops: 6 in [152.4 mm]
Loading method:	Rack and pinion, lever can be positioned in 30° increments
Travel Rate:	3 in [76.2 mm] per lever rev.
Weight:	12 lb [5.4 kg]
Included accessories:	Force gauge mounting hardware
Warranty:	3 years (see individual statement for further details)

Optional Equipment

Digital travel display TSB001	6 in [150 mm] travel, 0.0005 in [0.01 mm] resolution, 0.001 in [0.03 mm] accuracy, SPC output for data collection.
Horizontal / wall mounting kit TSA002	Converts the TSA750 to a TSA750H
Travel stops kit TSB003	Pair of adjustable travel stops for setting travel limits during testing

>> Digital travel display



Dimensions

in [mm]

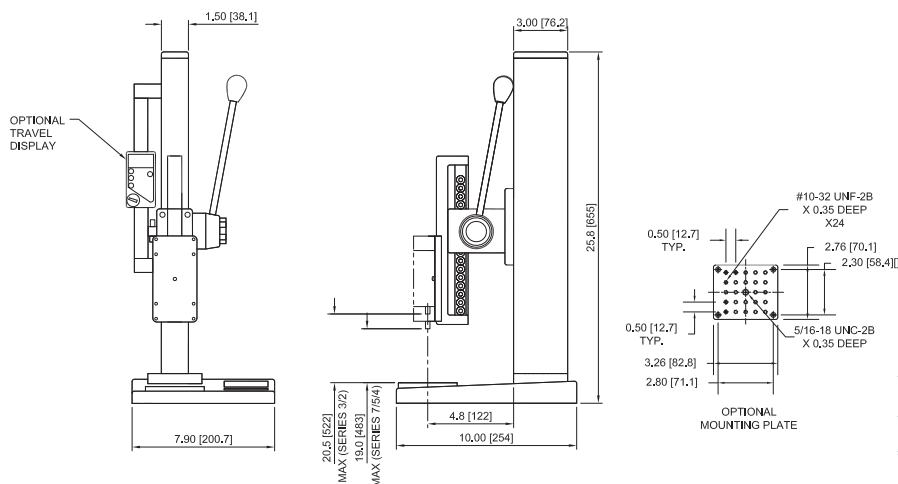

The TSB100 is shown with a Series 5 force gauge

Ordering Information

Model No.	Description
TSB100	Test stand, lever-operated, 100 lbf, vertical
TSB001	Digital travel display for TSA750/TSA750H
TSA002	Horizontal / wall mounting kit
TSB003	Travel stops kit

