



GRAM DIAL™ GDK

PRECISION GRAM GAGE CAPACITIES: 10 TO 500 GF

- TENSION & COMPRESSION
- CAPACITIES: 10 TO 500 GF
- SEVEN MODELS
- LOW CLEARANCE TESTING
- PEAK FORCE HOLD
- ACCURACY: ± 1 GRADUATION



Detail of Flat Tip

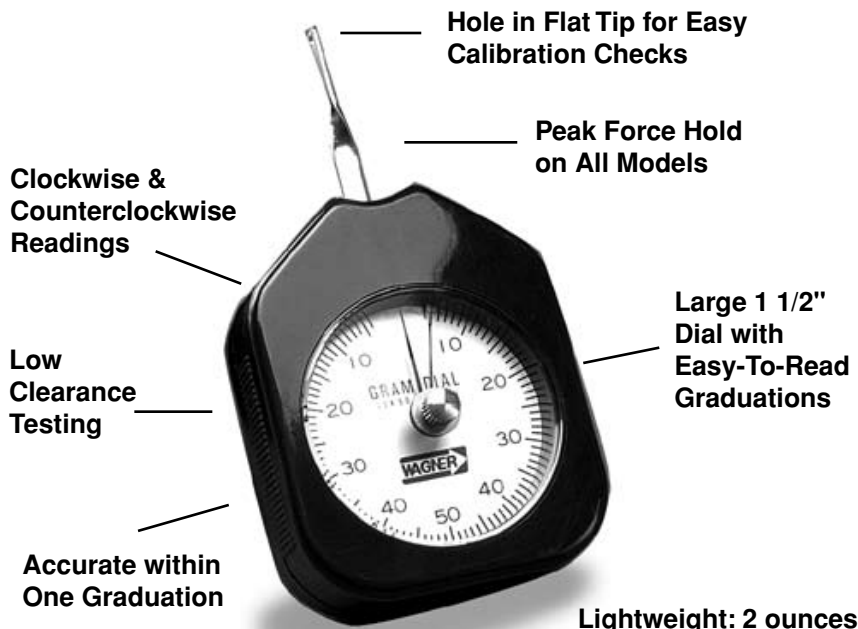

The **Wagner Gram Dial GDK Series** is an economical **cantilever arm** force gage for testing **tension and compression** at right angles to the force. The compact size and cantilever arm configuration facilitate force measuring in limited access areas or small openings. The flat tip design offers **line contact** with the test object and **incorporates a small hole** for hanging calibration weights or for attaching other test objects to the gage. Available in **seven capacities, 10 to 500 grams, Peak hold** is available on all models except the GDK 10.

- TIP CONFIGURATION:** Flat tip for line contact.
- TENSION /COMPRESSION:** Reads both clockwise and counterclockwise.
- PEAK FORCE POINTER:** Holds maximum force reading - available with most models.
- CALIBRATION:** Small hole in flat tip permits accuracy checks with test weights.
- DIAL DISPLAY:** Large 1 1/2" dial with easy-to-read graduations.
- ACCURACY:** Accurate to within one graduation.
- LIGHTWEIGHT:** All models: 2 ounces.

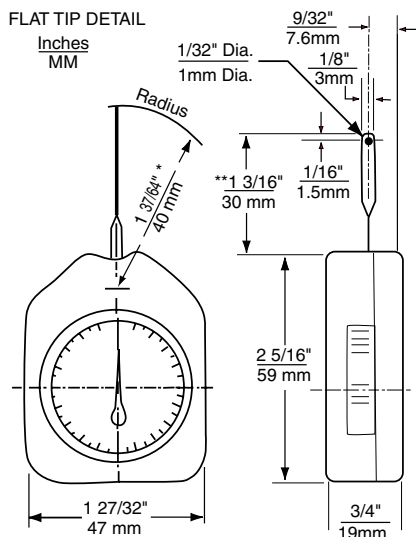

MODEL	CAPACITY/GRADUATION	PRICE
GDK 10*	1 - 10 gf x 0.5 gf	\$150
GDK 30	2 - 30 gf x 1 gf	150
GDK 50	4 - 50 gf x 1 gf	150
GDK 100	9 - 100 gf x 2 gf	150
GDK 150	10 - 150 gf x 5 gf	150
GDK 300	20 - 300 gf x 5 gf	150
GDK 500	40 - 500 gf x 10 gf	200

*Peak Force Hold not available on GDK 10.

Prices and specifications are subject to change without notice.

www.wagnerinstruments.com

CALL US TOLL FREE 800-345-4188



GRAM GAGE